

WG-5C Series Wall Guards

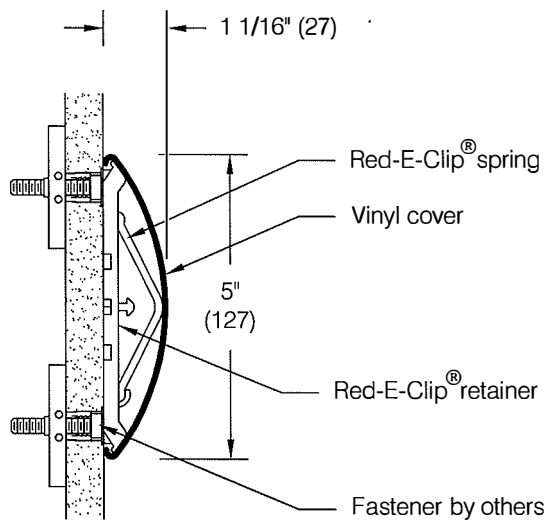

This installation instruction is applicable to:

WG-5C

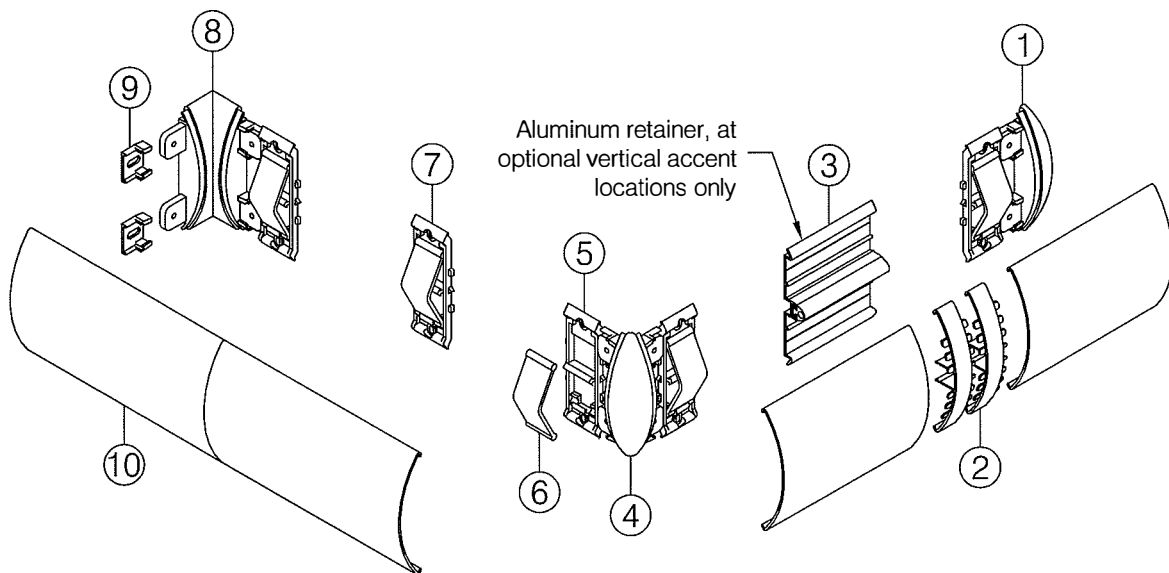

Component Part Numbers:

- 1.) ETC-5C Left/right end cap
- 2.) ACC-5 Vertical accent (optional)
- 3.) WGA-5 Aluminum retainer (at optional accents only)
- 4.) OTC-5C-0-XXX Outside corner with spacers
- 5.) WG-5C-CLIP-1 Red-E-Clip®retainer
- 6.) WG-8C-SPRING-11 Red-E-Clip®spring
- 7.) WG-5C-ASM-1 Red-E-Clip®spring and clip assembly
- 8.) ITC-5C-0-XXX Inside corner with spacers
- 9.) WG-8C-SPACER-1 Accessory spacer
- 10.) WGV-5-12-XXX Vinyl cover

Step 1: Determine top of wall guard height and snap a chalk line 2 ½" below to locate centerline of wall guard and to provide a reference line for locating WG-5C Red-E-Clip® retainers, see **fig 1**.

Important: Store material in a clean dry place where the temperature is maintained above 50°F (10°C). Walls and rooms should be maintained at a minimum of 65°F (18°C) for at least 48 hours prior to installation. Acclimate materials to normal building conditions for at least 24 hours before cutting and installing.

Step 2: Each Red-E-Clip® retainer consists of a base or "Clip" and an impact cushion or "Spring" shipped separately, see **fig 2**. Secure clips to wall by aligning the molded location pointers in the clip with the chalk line, see **fig 3**. While the clip may be installed either end up it is recommended that the spring socket be oriented down, see **fig 8**.

Note: A continuous metal backer plate should be used in all drywall installations to allow freedom in the left-to-right placement of the Red-E-Clip®. In the absence of a backer plate align each clip with a metal stud. When necessary a clip may be installed away from a stud or backer plate using the appropriate hardware, see **step 4** below.

Red-E-Clip® must be:

- Spaced not to exceed 16" on center
- Located adjacent to end cap and corner accessories, see **step 3**
- At each WGV-5 cover butt-joint, see **fig 7**

Step 3: A Red-E-Clip® must be installed adjacent to each molded accessory. Begin by installing a spacer on each of the accessory mounting tabs, see **fig 4**. The Red-E-Clip® has four accessory alignment tabs used to facilitate positioning of the molded components with respect to the clip, see **fig 5**. Temporarily locate the accessory and Red-E-Clip® combination by holding them temporarily in their desired position. Remove the accessory and fasten the Red-E-Clip® in place. It is also possible to locate the clip by measuring 3 7/8" to 3 15/16" from the outer edge of the desired accessory location or 1" to 1 1/16" from the inner edge, see **fig 6**.

Note: It is critical to install the clip and the accessory perpendicular to the chalk line to ensure a proper fit with the square cut WGV-5 cover.

Step 4: Secure Red-E-Clip® assemblies to wall with the appropriate hardware according to wall condition.

Suggested hardware :

- Drywall with metal backing : #8 Drill point drywall screw or #8 pan head or hex washer head sheet metal screw.
- Drywall without stud or backing : Plastic Alligator® insert with #8 pan head or hex washer head sheet metal screw or 3/16" Toggler® brand toggle bolts with pan head machine screw.
- Masonry : Plastic Alligator® insert with #8 pan head or hex washer head sheet metal screw or 3/16" hex washer head Tapcon® (or similar fastener).

Step 5: Secure the accessory component in place using the Red-E-Clip® alignment tabs as a guide. Be certain to adjust the accessory as required to ensure it is square with the chalk line. Install with hardware described in **step 4**.

Step 6: Double check to ensure all springs are snapped in place.

Note: Install spring by snapping ball of spring into socket provided in clip. The easiest method is to locate the ball opposite the socket against the "stops" provided in the clip and snap the ball into the socket by pressing the crown of the spring both down and toward the socket, see **fig 8**.

Step 7: If optional ACC-5 vertical accents are being used snap fit them on aluminum retainer in locations desired. If accents are being used side-by-side slide them together after they are snapped in place so that the interlocking teeth pass under the next accent in sequence. The teeth will interlock properly only when all accents are aligned the same way, see **fig 9**. Aluminum retainer length to accommodate accents and 2" of WGV-5 cover on both sides of accents.

Step 8: Measure between accessories, including optional vertical accents where used, and cut the WGV-5 vinyl cover. Miter cut the WGV-5 for all special angle corners not accommodated by the molded accessories. Install a Red-E-Clip® retainer centered at each WGV-5 butt-joint location, see **fig 7**.

Important: All WGV-5 cuts must be square and deburred.

Step 9: Snap the WGV-5 cover in place.

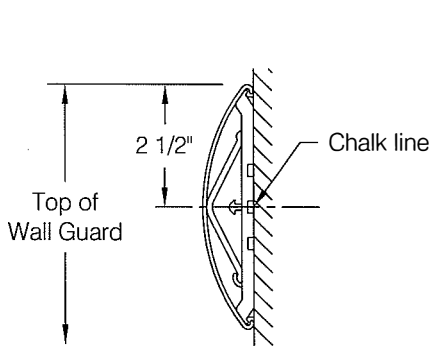

fig 1

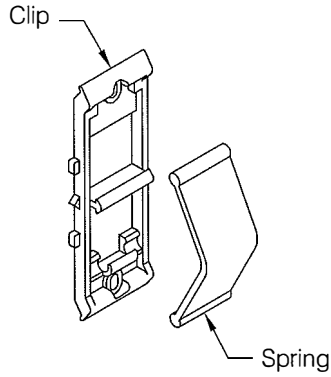

fig 2

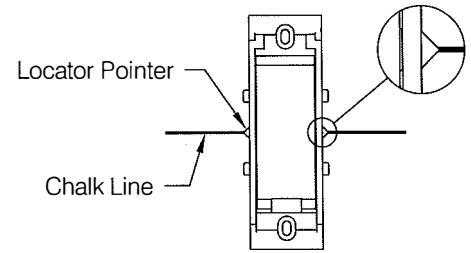

fig 3

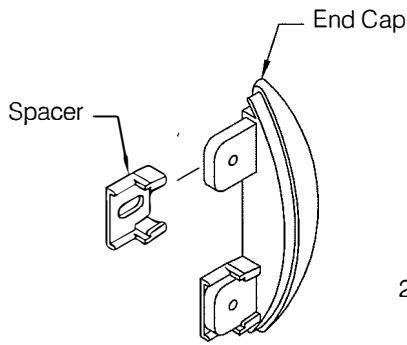

fig 4

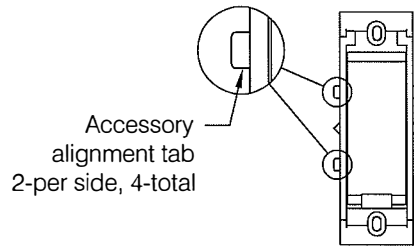

fig 5

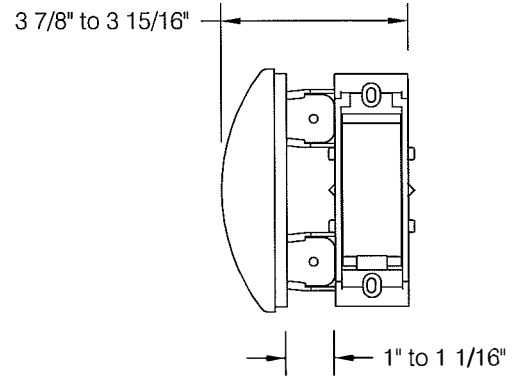

fig 6

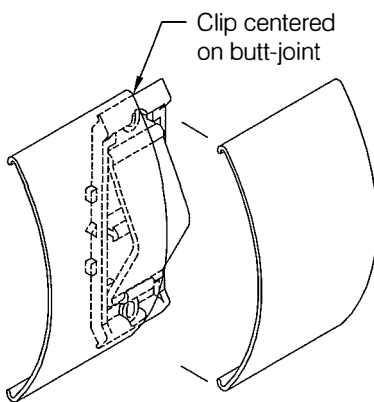

fig 7

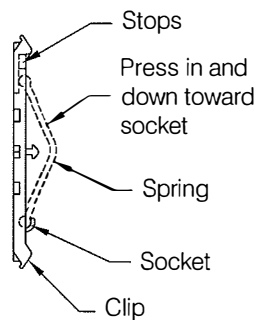

fig 8

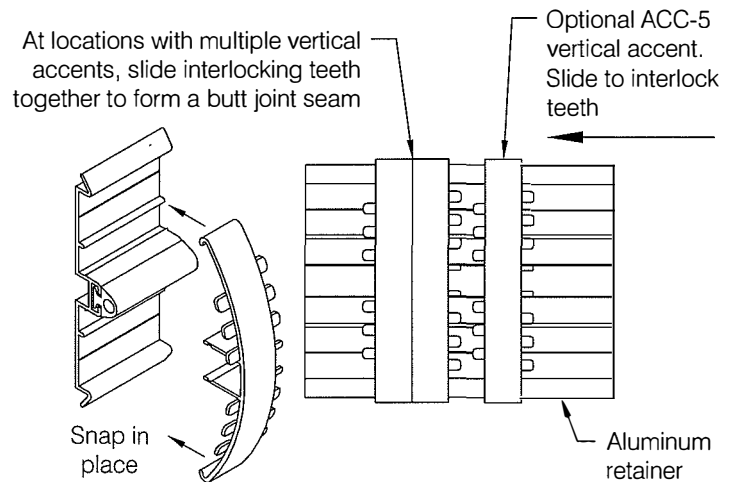
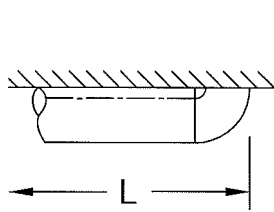
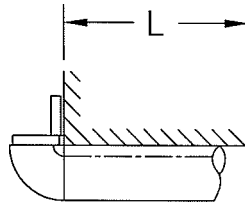

fig 9

Cutting Adjustment Diagrams and Schedule



End Cap



Outside Corner

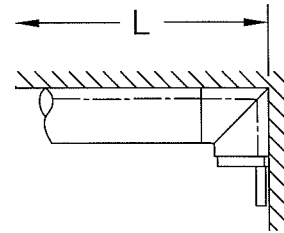

Inside Corner

Vinyl Cover

End Cap	$L - 1 \frac{1}{16}''$
Outside Corner	$L - 0''$
Inside Corner	$L - 1 \frac{3}{8}''$

Important: install Red-E-Clip retainers and molded accessories before cutting the snap-on cover.

Minimum Layout Configurations

