

CGT-12, CGT-13, CGT-14, CGT-34 & CGT-1245 Surface Mounted Corner Guards

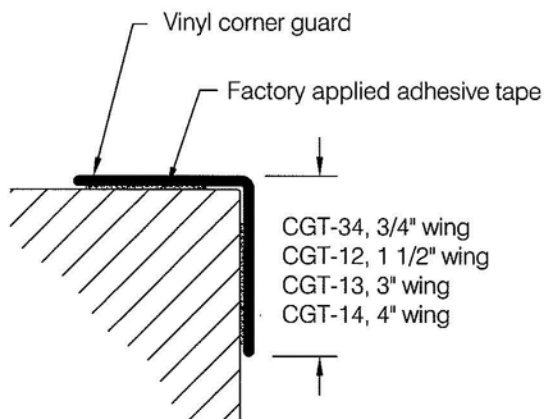

90° Corner Guards

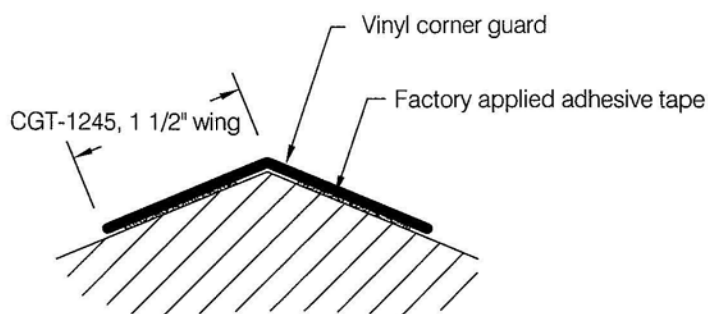

135° Corner Guard

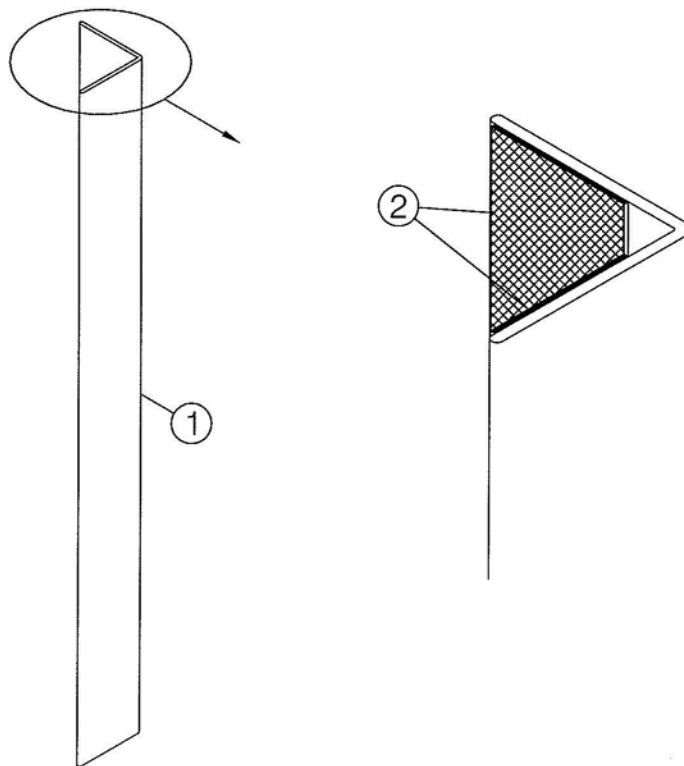

Component Part Numbers:

- 1.) Extruded corner guard with adhesive tape applied
 CGT-34, CGT-12, CGT-13, CGT-14, CGT-1245
- 2.) Factory applied adhesive tape, full length on inner
 face of each wing

CGT-12, CGT-13, CGT-14, CGT-34 & CGT-1245 Surface Mounted Corner Guard Installation Instructions

- Step 1:** This series of corner guards is supplied with a closed-cell foam adhesive tape applied to the inner surface of each wing. The adhesive tape is applied to the full length of the corner guard, see **fig 1**.
Note: The corner guard is pre-cut at the factory and requires no further trimming. If it is necessary to alter the corner guard length, use a fine tooth carbide tipped blade. All cuts must be square and deburred.
- Critical:** Product must be installed at a minimum of 65°F (18°C) to ensure proper adhesion. Walls and rooms should be maintained at a minimum of 65°F (18°C) for at least 48 hours prior to installation. Acclimate materials to normal building conditions for at least 24 hours before cutting and installing. Prior to acclimation and installation, material may be stored in a clean dry place where the temperature is maintained above 50°F (10°C) and is not allowed to exceed 100°F (38°C). Do not store in exposed sunlight.
- Step 2:** The adhesive foam carrier is flexible and will conform to fill small surface irregularities, however, this corner guard series is not recommended for installation on rough surfaces. Proper adhesion to the intended substrate requires contact with the maximum surface area possible. Do not attempt to install on corners that require more than light finger pressure to make contact.
- Important:** The surface to which the corner guard will be applied must be clean and free of dust, oils, adhesive residue, or any foreign material that might interfere with the adhesive bond.
- Step 3:** Select the mounting location and test fit the corner guard by holding it in place before exposing the adhesive. Make sure there is no interference with adjacent construction and correct any problems that might interfere with obtaining full surface contact.
- Step 4:** Remove the paper release liner from each adhesive tape. Do not handle the exposed adhesive or allow it to become contaminated with foreign matter or materials that might reduce the adhesive bond.
- Hint:** There are many ways to apply the corner guard. Regardless of how it is accomplished, a critical step in the process is making *firm contact* between the substrate and adhesive on *both wings*. One method that can be used to avoid misalignment is to remove one liner completely and peel the second back just far enough to allow it to be grasped and removed with the corner guard in place, see **fig 2a** and **2b**. Install by resting the face with the liner lightly against the wall and then seat the face with the exposed adhesive tightly in place. Once secure, grasp the liner and carefully pull downward and outward to peel it from the adhesive. Do not use this method if the liner left in place has nicks or tears that may cause the liner to tear before it is removed completely.
- Step 5:** Seat firmly in place by using a roller to apply pressure to the full surface area of the corner guard. Choose a roller that will not damage the exposed surface.
- Step 6:** Discard the release liners.

