

D-4 Extruded Bumper

Features:

- Extruded EPDM rubber to RMA tolerances
- Durometer: (ASTM D-412) 70 ±5 shore A
- Tensile strength PSI: (ASTM D-412) 1,750 min.
- Elongation: (ASTM D-412) 395 min.
- Tear strength: (ASTM D-624) 229 lbs./in. Min.
- Impact resistance: (ASTM 2632) 75%
- Low temp brittleness: (ASTM D-746) -40 degrees F min.
- Ozone: (ASTM D-1171) 1142 hrs @ 102 degrees F; 20% strain - no cracks
- Deflection: (ASTM D-575) 60,000 ft./lbs. 60,000 ft./lbs. - 3" (76) with no ruptures
- Stock length: 12'-0" (3658) Black
 12'-0" (3658) Yellow
 10'-0" (3048) Gray

Optional Features:

- Drilled for hardware:
 Approximately 12" (305) on center
 Spacing from end varies as restricted by length
- Custom drilling available
- Urethane end cap, (EP-4) black only

Standard Colors:

- Black #1
- Gray #5
- Yellow #12

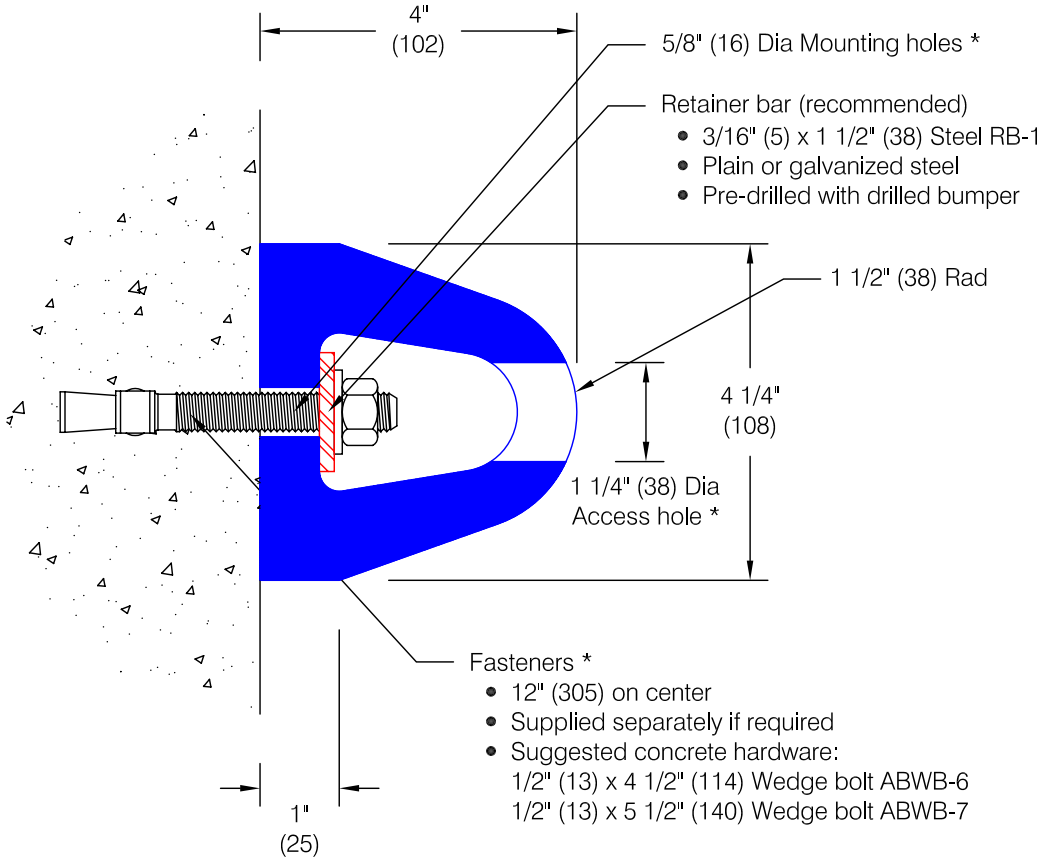

* Standard bumper is supplied undrilled and with no mounting hardware. Hole spacing shown for bumpers 48" (1219) and longer. Contact factory for hole spacing on lengths shorter than 48" (1219).

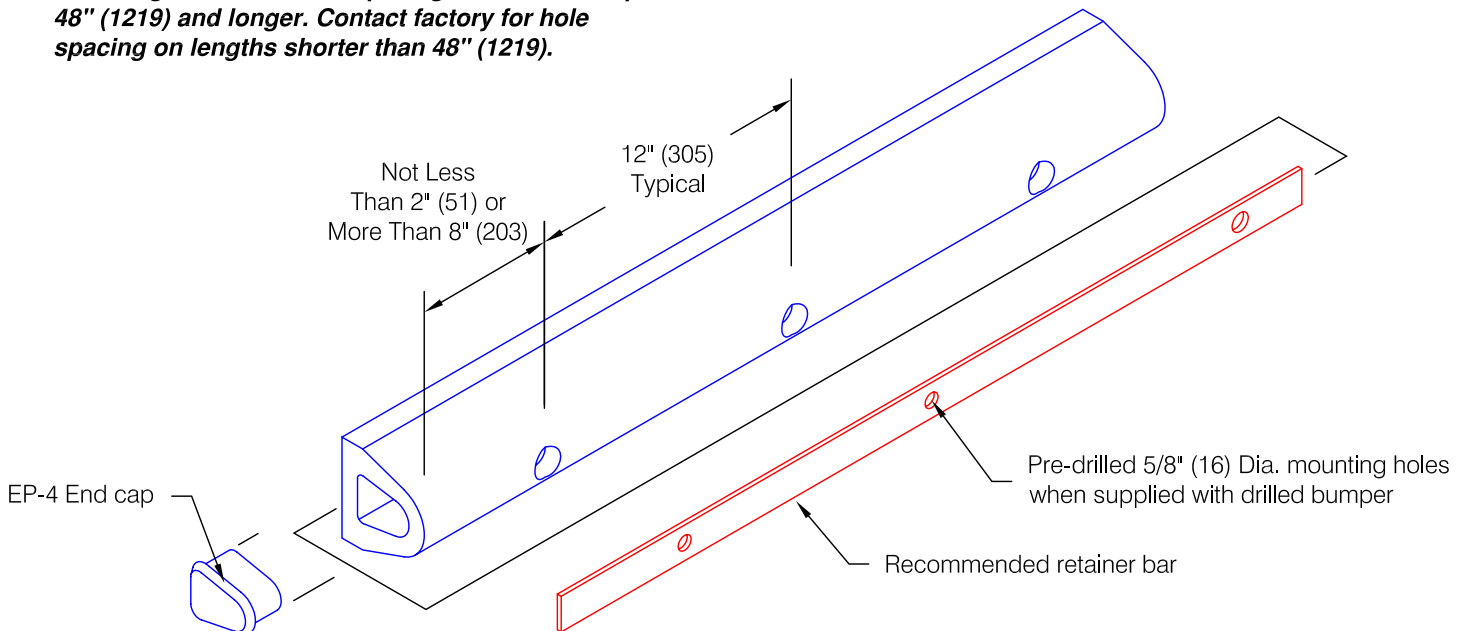

Customer :	Project :	CD.3.0c
Architect :	Sales Rep :	