

# ProTek Systems, Inc. Installation Instruction

## BR-400V Series Handrails

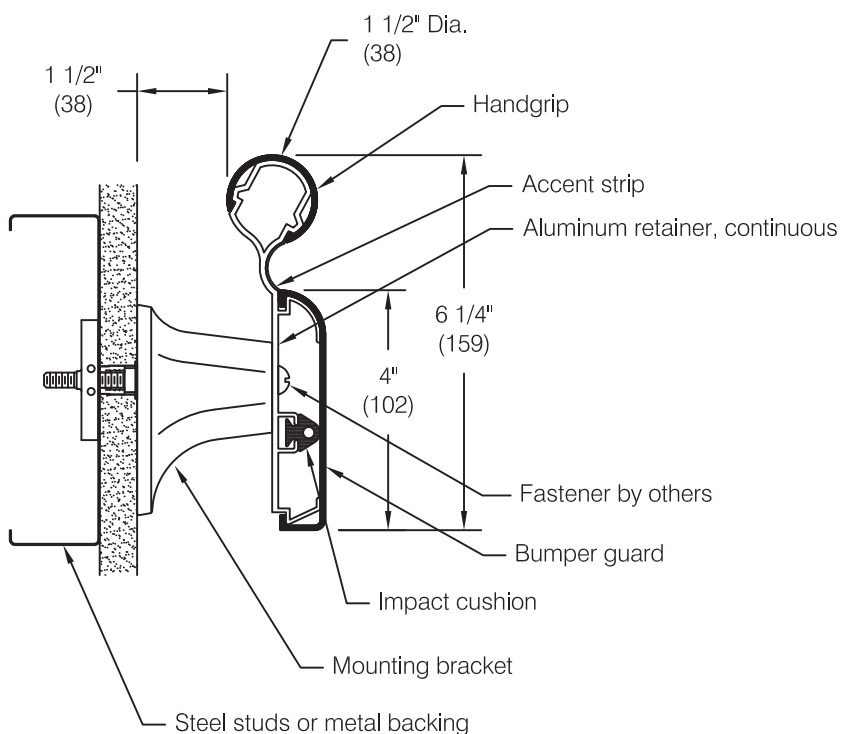

This installation instruction is applicable to:

BR-400V  
BR-400VG

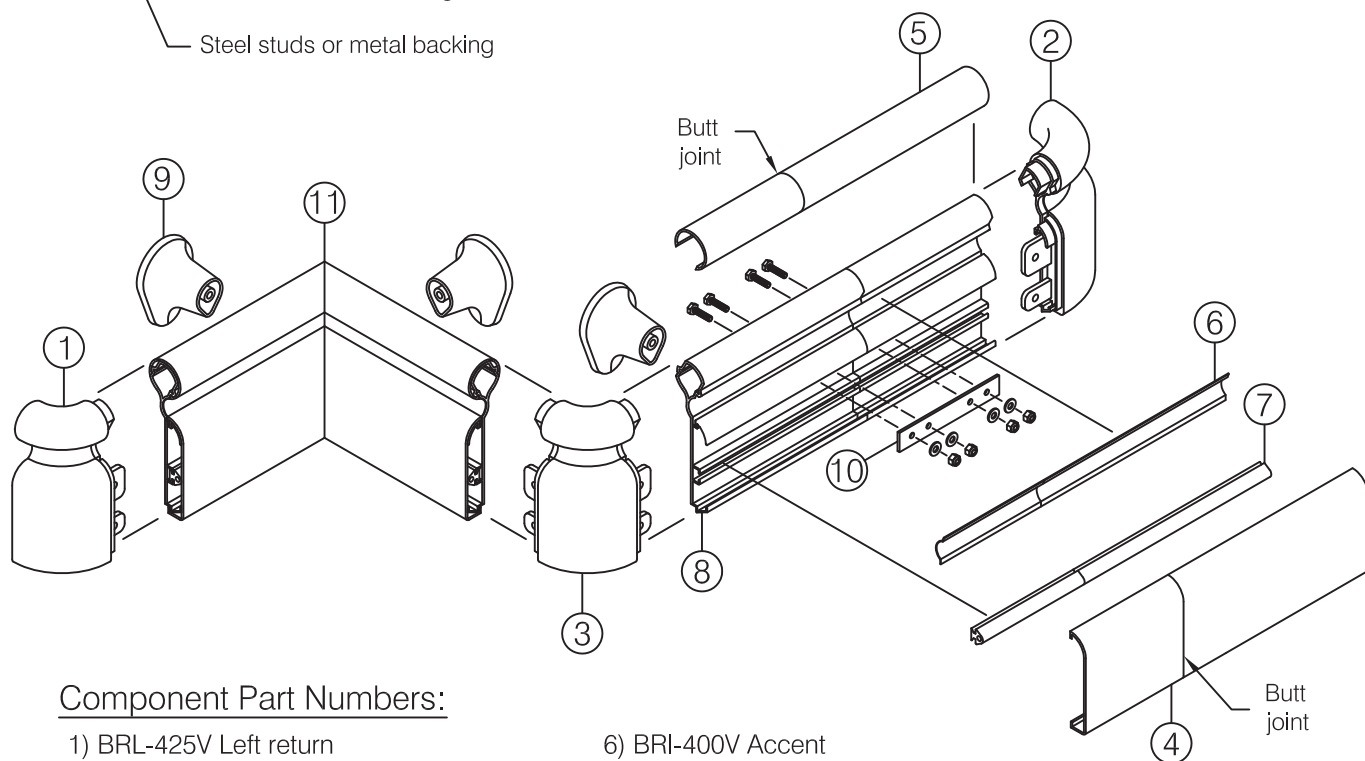

### Component Part Numbers:

- |  |                               |
|--|-------------------------------|
| 1) BRL-425V Left return  | 6) BRI-400V Accent            |
| 2) BRR-425V Right return   | 7) B-100 Impact cushion       |
| 3) OBR-450V Outside corner   | 8) BRA-400V Aluminum retainer |
| 4) Snap-on cover<br>WGV-4 Standard textured<br>WGVG-4 Grooved and textured | 9) BR-108 Mounting bracket    |
| 5) BRV-1200 Handrail cover   | 10) SPL-400 Splice            |
|  | 11) Field mitre inside corner |

## BR-400V Series Handrail Installation Instructions

**Step 1:** Determine top of handrail height and snap a chalk line 3 3/4" below for centerline of mounting hardware, see **fig 1**.

**Important:** Store material in a clean dry place where the temperature is maintained between 50°F (10°C) and 100°F (38°C). Walls and rooms should be maintained at a minimum of 65°F (18°C) for at least 48 hours prior to installation. Acclimate materials to normal building conditions for at least 24 hours before cutting and installing.

**Step 2:** Cut aluminum retainer. See **Cutting Adjustment Diagrams and Schedule** for adjustments to aluminum retainer length at wall returns, inside corners and outside corners. Refer to **Minimum Layout Configurations** for additional information.

**Important:** All cuts must be square and deburred.

**Step 3:** Layout aluminum retainer "face up", mark and drill bracket mounting hole locations.

**Bracket mounting holes must be spaced:**

- Not to exceed 32" on center
- 1 1/2" to 6" from end of aluminum retainer at returns and corner accessories
- A minimum of 4" from end of retainer at splices to avoid interference with splice hardware (shown in **fig 6**)
- To align with metal studs (on metal stud construction) or preferably with horizontal metal backer plate (by others)

*Note:* Use groove in retainer to locate centerline for drilling, see **fig 2**

**Step 4:** Locate and drill bracket mounting holes in wall construction using the aluminum retainer as a template or by careful measurement. Choice of hardware will dictate hole diameter.

**Step 5:** Insert molded accessories into end of retainer, press firmly to ensure molded part is seated squarely against the end of the retainer. Drill accessory mounting holes using the accessory as the template, see **fig 3**.

**Step 6:** Cut flexible cushion short enough to comfortably fit between molded accessories. Slide cushion into receptacle on aluminum retainer, see **fig 4**.

**Step 7:** Attach molded returns, outside corners and inside corners to retainer with accessory seated firmly and squarely while tightening. Fasten with 1/4" bolt, flat washer and nylon lock nut provided.

*Caution:* Do not use a lock washer, use flat washer only. Always place a flat washer between nut and molded tab. Tighten to 10 ft-lbs maximum torque, see **fig 5**.

**Step 8:** Mount assembly to wall with the appropriate hardware according to wall construction. See **step 9** for splicing information.

**Suggested hardware:**

- Drywall: Toggler® brand toggle bolts
- Masonry: Plastic Alligator® insert

**Step 9:** Refer to **fig 6** for splicing of aluminum retainer as required on longer handrail lengths. Always locate splice joints a minimum of 4" from bracket locations. For best results offset butt joint in cover, accent strip, and bumper guard from splice in aluminum retainer.

**Step 10:** Measure between accessories (corners and returns) and cut the handrail cover, accent, and bumper guard profiles. Cut profiles so they will span aluminum retainer butt joints.

**Important:** All cuts must be square and deburred.

**Step 11:** Place the accent strip in the finger groove of the aluminum retainer, ID mark down, see **fig 7**. Snap on the upper handrail cover then snap on lower bumper guard by hooking the upper leg first and then snap the lower hook into position.

# BR-400V Series Handrail Installation Instructions

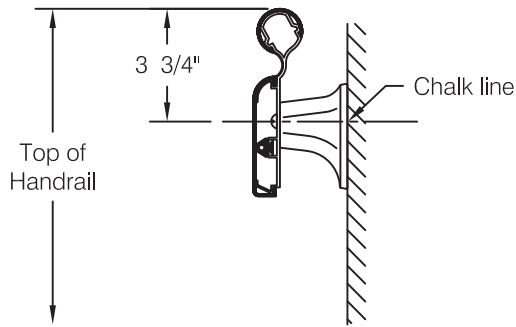

**fig 1**

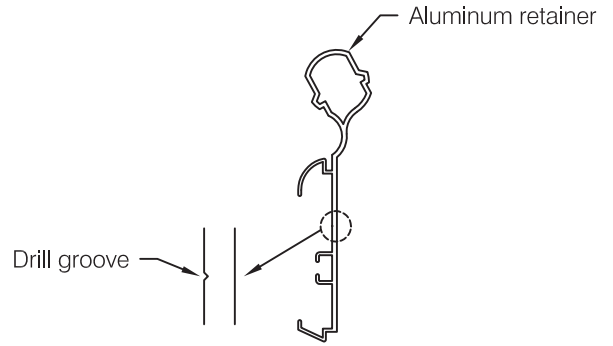

**fig 2**

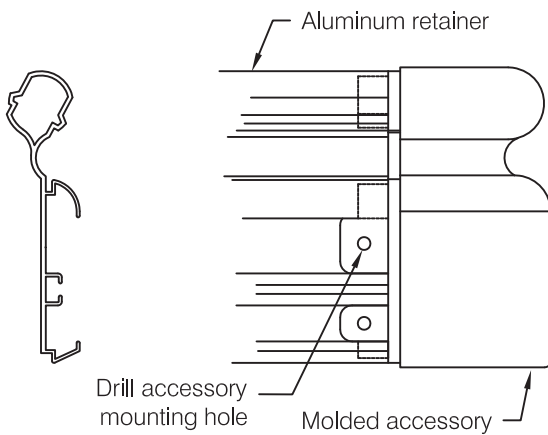

**fig 3**

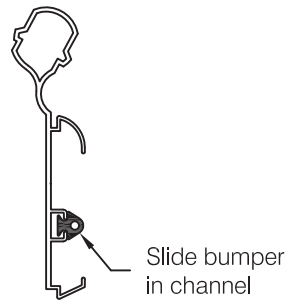

**fig 4**

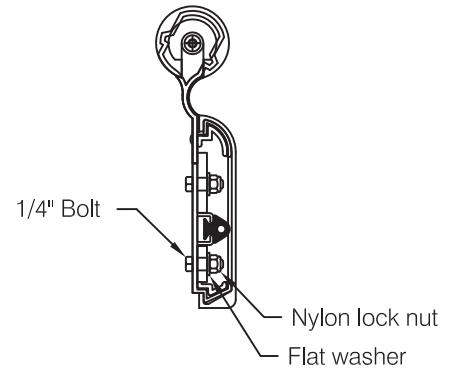

**fig 5**

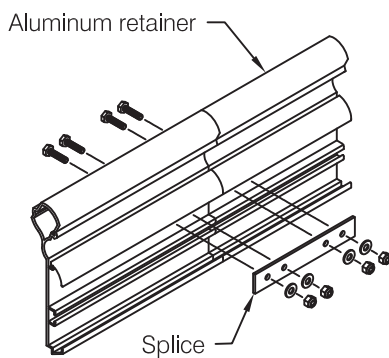

**fig 6**

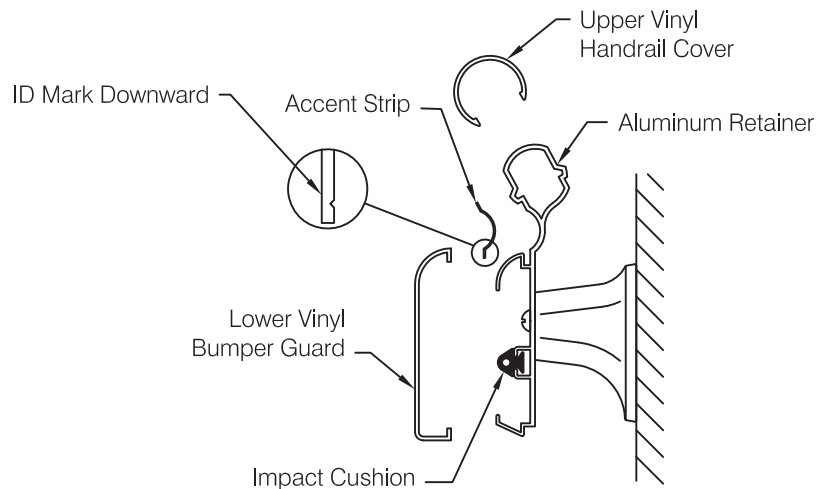

**fig 7**

# BR-400V Series Handrail Installation Instructions

## Cutting Adjustment Diagrams and Schedule

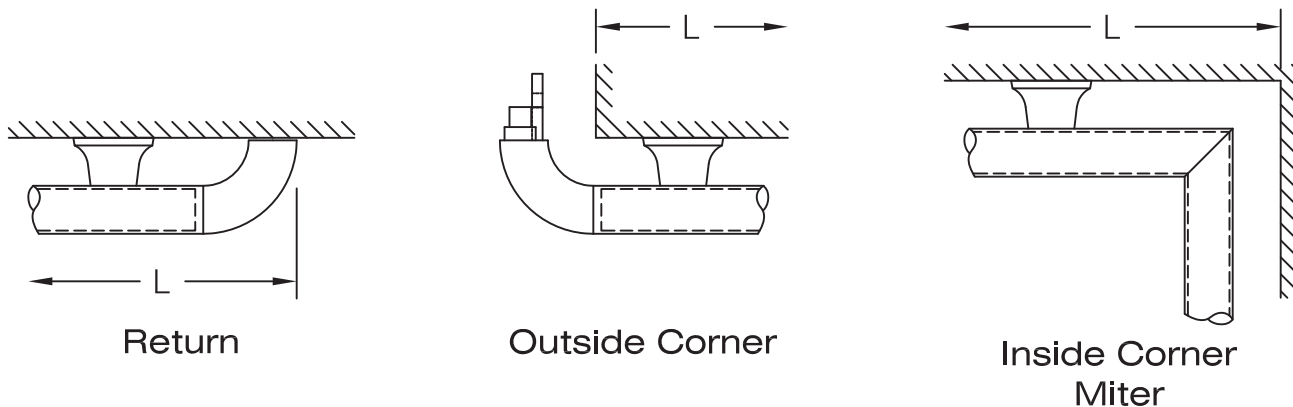

	Aluminum Retainer	Vinyl Cover
Return	L - 3 3/8"	L - 3 1/8"
Outside Corner	L - 3/16"	L + 1/16"
Inside Corner	Miter	Miter

Important: install aluminum retainer and molded accessories before cutting the snap-on cover.

## Minimum Layout Configurations

