

BR-500 Series Handrails

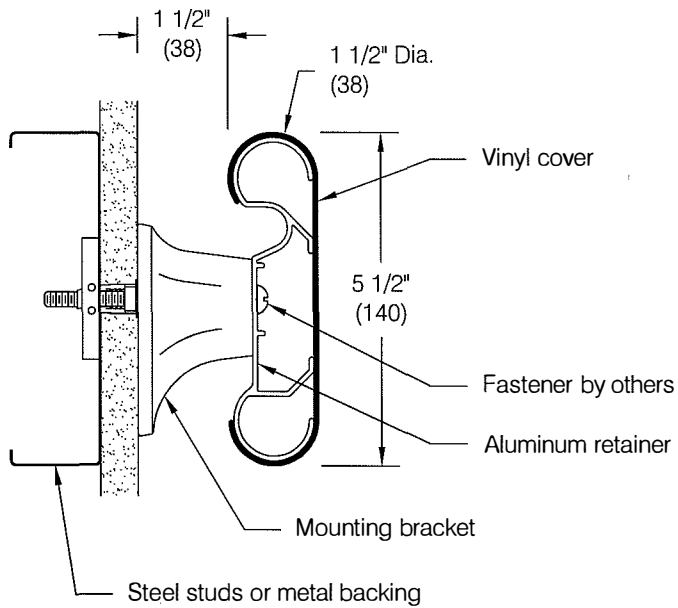

This installation instruction is applicable to:

- BR-500
- BR-500G
- BR-502

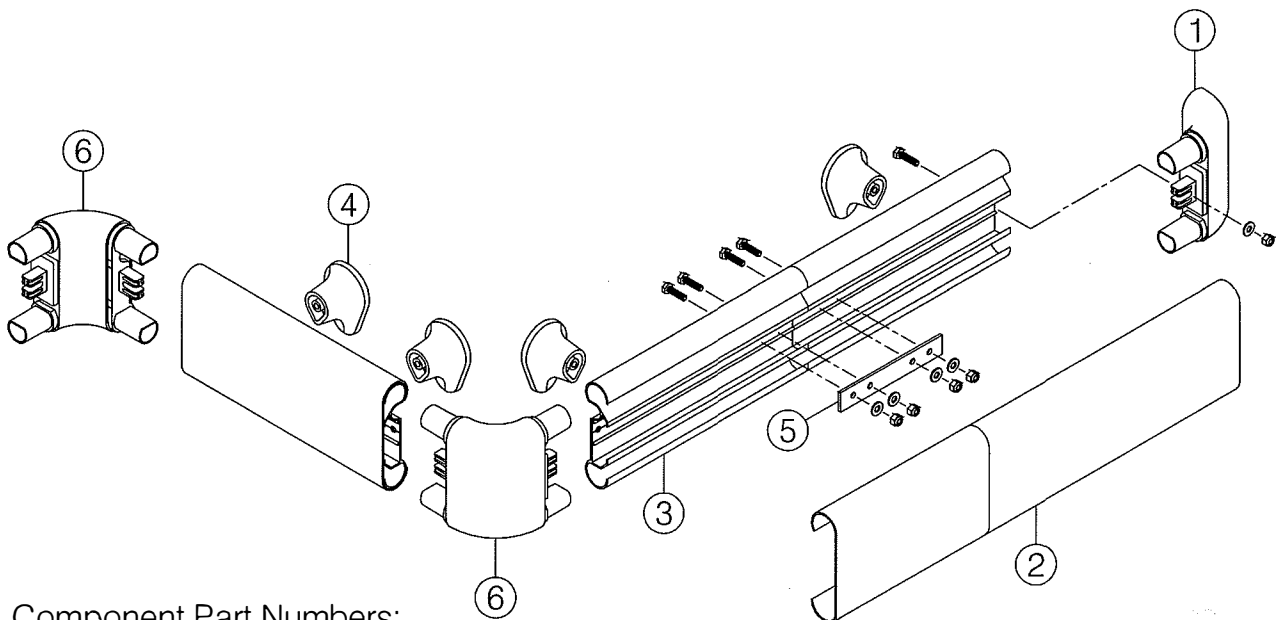

Component Part Numbers:

- 1.) BR-527 left/right return
- 2.) Snap-on cover
BRV-500 standard textured
BRVG-500 grooved and textured
BRV-502 accent stripe (1) and textured
- 3.) BRA-500 aluminum retainer
- 4.) BR-107 bracket
- 5.) SPL-500 splice
- 6.) IOC-557 inside/outside corner

BR-500 Series Handrail Installation Instructions

- Step 1:** Determine top of handrail height and snap a chalk line 2 ¾" below for centerline of mounting hardware, see **fig 1**.
- Important:** Store material in a clean dry place where the temperature is maintained above 50°F (10°C). Walls and rooms should be maintained at a minimum of 65°F (18°C) for at least 48 hours prior to installation. Acclimate materials to normal building conditions for at least 24 hours before cutting and installing.
- Step 2:** Cut aluminum retainer. See **Cutting Adjustment Diagrams and Schedule** for adjustments to aluminum retainer length at wall returns, inside corners and outside corners. Refer to **Minimum Layout Configurations** for additional information.
- Important:** All cuts must be square and deburred
- Step 3:** Layout aluminum retainer "face up", mark and drill bracket mounting hole locations.
Bracket mounting holes must be spaced:
- Not to exceed 32" on center
 - 1 1/2" to 6" from end of aluminum retainer at returns and corner accessories
 - A minimum of 4" from end of retainer at splices to avoid interference with splice hardware (shown in **fig 6**)
 - To align with metal studs (on metal stud construction) or preferably with horizontal metal backer plate (by others)
- Note:** Use groove in retainer to locate centerline for drilling, see **fig 2**
- Step 4:** Locate and drill bracket mounting holes in wall construction using the aluminum retainer as a template or by careful measurement. Choice of hardware will dictate hole diameter.
- Step 5:** Assemble inside and outside corner accessories by snapping corner insert into the molded return, see **fig 3**. Always install the insert with finger notch up and in toward wall. It may be necessary to reverse the position of the molded return to accomplish the correct insert orientation.
Note: Symmetry of the molded return accessory allows for installation in the aluminum retainer in any orientation. The correct choice will allow for proper installation of the insert to form inside and outside corners.
- Step 6:** Insert molded accessories into end of retainer, press firmly to ensure molded part is seated squarely against the end of the retainer. Drill accessory mounting holes using the accessory as the template, see **fig 4**.
- Step 7:** Attach molded returns, outside corners and inside corners to retainer with accessory seated firmly and squarely while tightening. Fasten with ¼" bolt, flat washer and nylon lock-nut provided.
Caution: Do not use a lock washer, use flat washer only. Always place a flat washer between nut and molded tab. Tighten to 10 ft-lbs maximum torque, see **fig 5**.
- Step 8:** Mount assembly to wall with the appropriate hardware according to wall construction. See **step 9** for splicing information.
Suggested hardware:
- Drywall: Toggler® brand toggle bolts
 - Masonry: Plastic Alligator® insert
- Step 9:** Refer to **fig 6** for splicing of aluminum retainer as required on longer handrail lengths. Always locate splice joints a minimum of 4" from bracket locations. For best results offset butt joint in cover from splice in aluminum retainer.
- Step 10:** Measure between accessories (corners and returns) and cut vinyl cover.
Important: All cuts must be square and deburred
- Step 11:** Snap on the vinyl cover.

BR-500 Series Handrail Installation Instructions

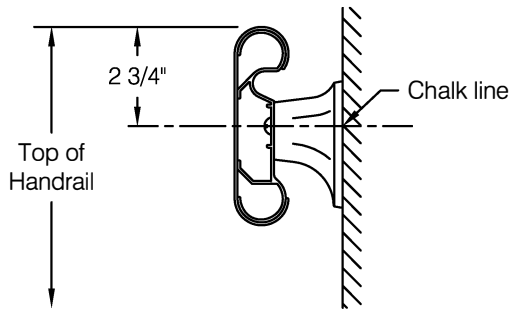

fig 1

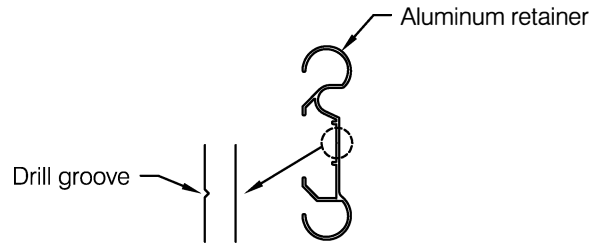

fig 2

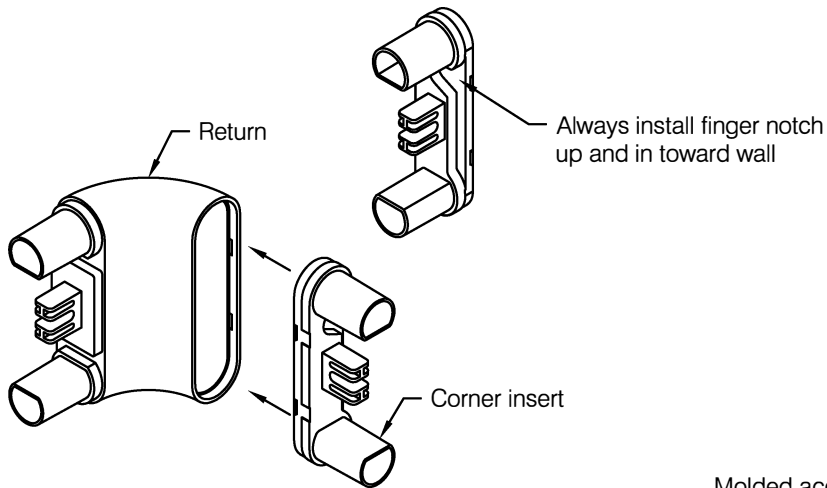

fig 3

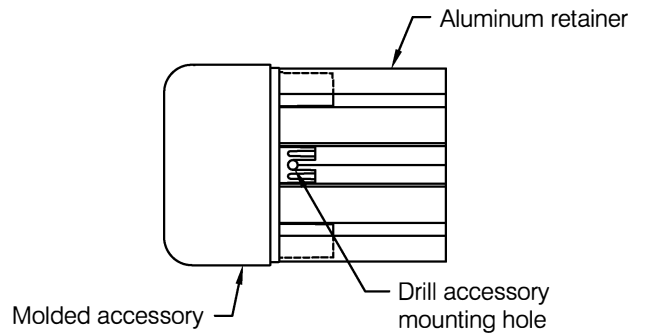

fig 4

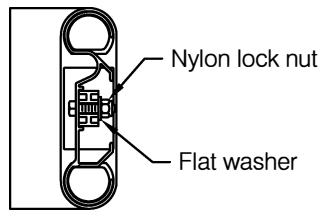

fig 5

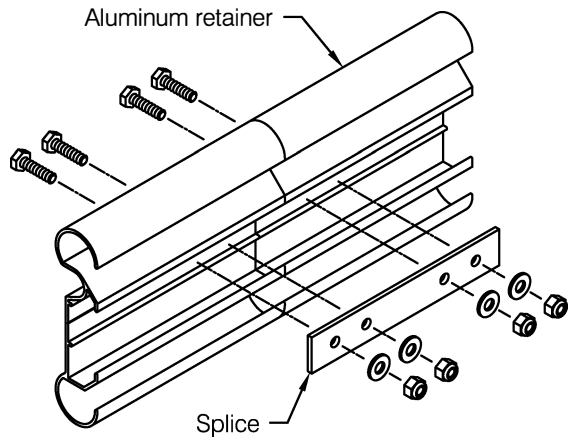
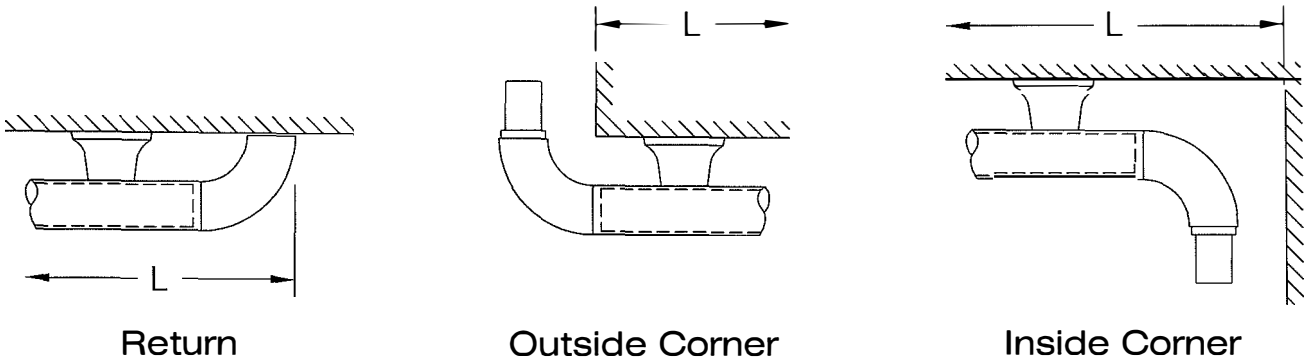

fig 6

BR-500 Series Handrail Installation Instructions

Cutting Adjustment Diagrams and Schedule



	Aluminum Retainer	Vinyl Cover
Return	L - 3 3/16"	L - 2 15/16"
Outside Corner	L - 3/16"	L + 1/16"
Inside Corner	L - 4 11/16"	L - 4 7/16"

Important: install aluminum retainer and molded accessories before cutting the snap-on cover.

Minimum Layout Configurations

